



**WOT DIGITAL SERVICES PRIVATE LIMITED**

**Mob: +91-9518203119**

**info@wotdgroup.com**

**WTD-1000**

**Tripod Turnstile**

**Features**

Dimension: 480\*280\*960mm

Unlock Time: 0.2s

Pass Rate: 35Person/min.

Pass Width: <550mm

Input: 100V~240V

Motor Voltage: 24v

Environment: -25~+70

Power Consumption: 30w

Protection Level- IP45



**Benefits**

All turnstile models are space efficient security barriers, with a compact design,yet offer sufficient space to integrate any access control system.They can be mounted with display, passage counter, card reader, token operation traffic lights, command console,alarm system against unauthorized entries,The unique dropping arm feature provides a fail safety solution in case of an emergency or power failure,Tproviding egress in case of crisis evacuations. Durability with minimal maintenance means years and millions of trouble free passages. The turnstile creates a secure environment in. for example, a reception area. Our turnstile are used in different applications including stadiums and arenas, perimeter and interior security, recreation and amusement parks, retail crowd control, transit fare collection and lobby access control.

**Diagram**

Access Control System

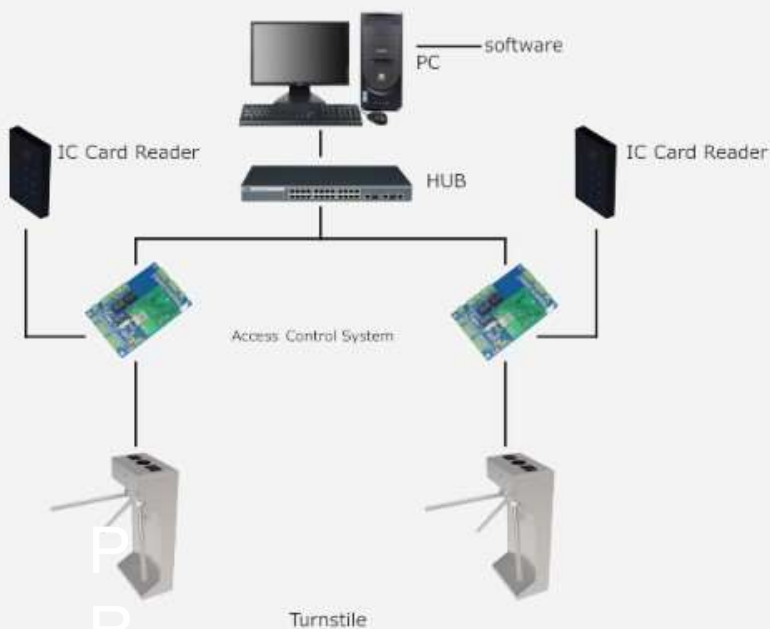

**Dimension**

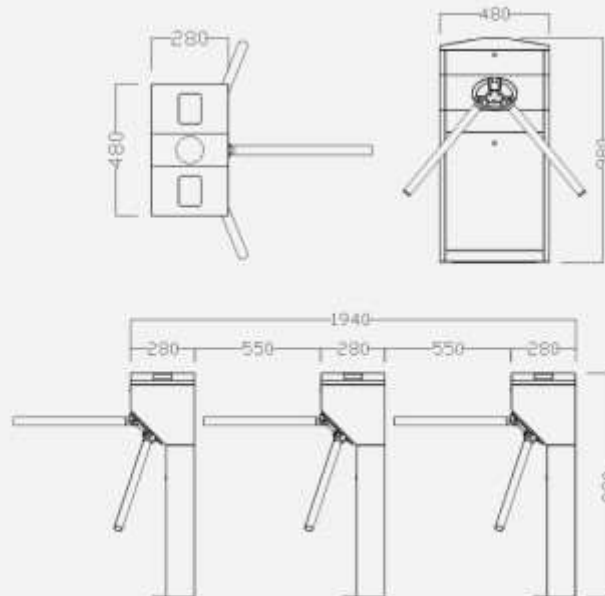

\*Color/Look may vary from actual product.